



Direct Vent

Gas Water Heater

Quiet, reliable and efficient operation in a quality design: the GSW Direct Vent water heater. The balanced flue design with a side wall vent termination allows installation in locations without a chimney. The sealed combustion chamber and co-axial vent uses fresh air taken from outside rather than compromising indoor air quality. Ideal for applications where space is at a premium.

Features

Designed for Performance

- Thermopile design provides robust pilot to withstand down drafts and environmental conditions
- LED indicator:
 - Gives visual confirmation that pilot is on by flashing continuously
 - Provides diagnostics and troubleshooting
- Easy temperature adjustments
- Direct vent design means no external power supply or chimney required for operation/installation
- 90" Coaxial vent supplied with water heater
- Top mounted heavy duty anode rod for added tank protection
- Galvanized bottom pan protects from corrosion
- Glass-lined tank for longer life
- Factory-installed plastic-lined nipples with heat traps
- CFC-free foam insulation
- Suitable for closet installations

Safety Features

- Sealed Combustion Chamber design, eliminating the need for FV sensor

Serviceability

- Combustion chamber is easy to access
- Conveniently located T&P and drain valve for ease of installation and serviceability



WARRANTY

6 Year Limited Tank Warranty

1 Year Limited Parts Warranty

Consult installation manual for terms and conditions or visit www.gsw-wh.com for more information.



Direct Vent Gas Water Heater

PERFORMANCE						
Model	Capacity	Maximum Certified Altitude	Input	Recovery Rate at 100°F/55°C Temp. Rise	First Hour Rating	Energy Factor
	USG (L)	ft (m)	BTU/hr	USG (L)	USG (L)	
NATURAL GAS						
6G40BFNA-FV Series 10	40 (151)	5,400 (1,646)	38,000	34 (129)	73 (286)	0.60
6G50TFBNA-FV Series 10	50 (189)	5,400 (1,646)	42,000	38 (144)	87 (329)	0.58
PROPANE						
JW40BFP-FV Series 11	40 (151)	5,400 (1,546)	38,000	34 (129)	73 (286)	0.60
JW50TFBNA-FV Series 11	50 (189)	5,400 (1,646)	42,000	38 (144)	87 (329)	0.58

Note: Propane models will be John Wood brand.

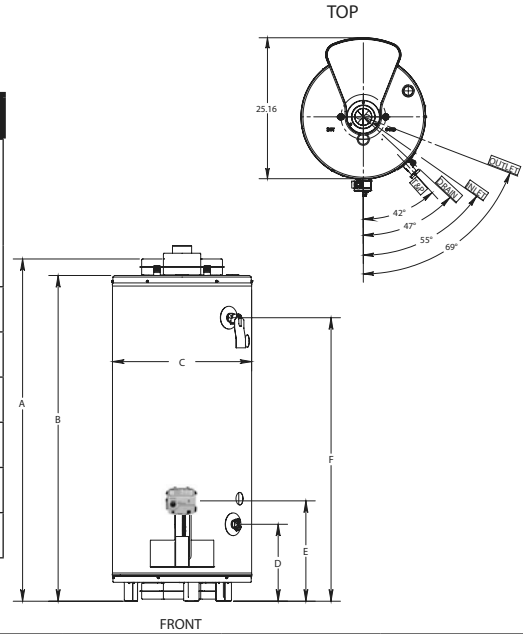

DIMENSIONS & SHIPPING WEIGHT							
Model	Installation Height	Height to Top of Tank	Tank Diameter	Height to Drain Valve	Height to Gas Inlet	Height to T&P Valve	Approx. Shipping Weight
	A in (cm)	B in (cm)	C in (cm)	D in (cm)	E in (cm)	F in (cm)	lb (kg)
NATURAL GAS							
6G40BFNA-FV Series 10	56 3/4 (144)	52 (132)	22 1/4 (57)	12 1/4 (31)	16 (40)	45 1/4 (114)	167 (76)
6G50TFBNA-FV Series 10	65 3/4 (167)	61 (155)	22 1/4 (57)	12 1/4 (31)	16 (40)	54 (137)	185 (84)
PROPANE							
JW40BFP-FV Series 11	56 3/4 (144)	52 (132)	22 1/4 (57)	12 1/4 (31)	16 (40)	45 1/4 (114)	167 (76)
JW50TFBNA-FV Series 11	65 3/4 (167)	61 (155)	22 1/4 (57)	12 1/4 (31)	16 (40)	54 (137)	185 (84)

